

Z371/...

Mat.: 1.4305

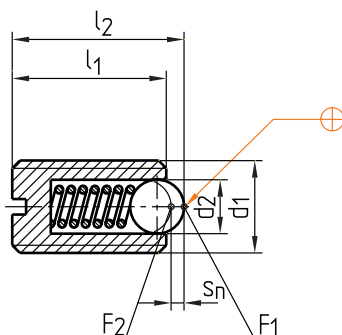

max. °C	$d_2$	$s_n$	$F_1$ [N]	$F_2$ [N]	$l_2$	$d_1$	$l_1$	Nr./No.
250	2,5	0,64	6	11,6	9,8	<b>M 4</b>	<b>9</b>	Z371/ 4x 9
	3	0,72	8,8	13,3	12,9	<b>M 5</b>	<b>12</b>	5x12
	3,5	0,8	11,2	15,1	15	<b>M 6</b>	<b>14</b>	6x14
	5	1,2	18,5	29,5	17,5	<b>M 8</b>	<b>16</b>	8x16
	6	1,6	23,9	43	21	<b>M10</b>	<b>19</b>	10x19
	8	2	35,9	59,8	24,5	<b>M12</b>	<b>22</b>	12x22
	10	2,4	74	101,6	27	<b>M16</b>	<b>24</b>	16x24

Z372/...

Mat.: 1.0718

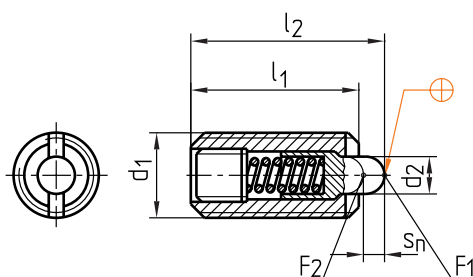

max. °C	$d_2$	$s_n$	$F_1$ [N]	$F_2$ [N]	$l_2$	$d_1$	$l_1$	Nr./No.
250	1	0,8	1,7	2,8	13	<b>M 3</b>	<b>12</b>	Z372/ 3x12
	1,5	1,2	5	12	16,5	<b>M 4</b>	<b>15</b>	4x15
	2,4	1,8	7	16	20,3	<b>M 5</b>	<b>18</b>	5x18
	2,7	2			22,5	<b>M 6</b>	<b>20</b>	6x20
	3,5	2,4	9	28	25	<b>M 8</b>	<b>22</b>	8x22
	4					<b>M10</b>		10x22
	6	3,2	15	44	32	<b>M12</b>	<b>28</b>	12x28
	7,5	4	45	80	37	<b>M16</b>	<b>32</b>	16x32
	10	5,6	70	112	47	<b>M20</b>	<b>40</b>	20x40
	12	8	80	144	62	<b>M24</b>	<b>52</b>	24x52

This is trial version  
www.adultpdf.com